

LOW NOISE GENERAL PURPOSE AUDIO AMPLIFIERS

DESCRIPTION

The BC107, BC108 and BC109 are silicon planar epitaxial NPN transistors in TO-18 metal case. They are suitable for use in driver stages, low noise input stages and signal processing circuits of television receivers. The complementary PNP types are respectively the BC177, BC178 and BC179.

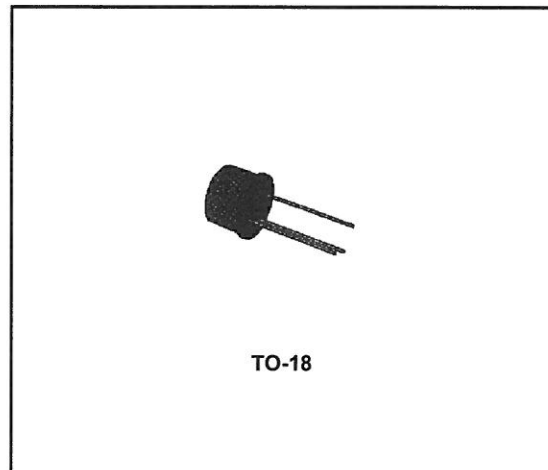

INTERNAL SCHEMATIC DIAGRAM



ABSOLUTE MAXIMUM RATINGS

Symbol	Parameter	Value			Unit
		BC107	BC108	BC109	
V_{CBO}	Collector-base Voltage ($I_E = 0$)	50	30	30	V
V_{CEO}	Collector-emitter Voltage ($I_B = 0$)	45	20	20	V
V_{EBO}	Emitter-base Voltage ($I_C = 0$)	6	5	5	V
I_C	Collector Current	100			mA
P_{tot}	Total Power Dissipation at $T_{amb} \leq 25\text{ }^\circ\text{C}$ at $T_{case} \leq 25\text{ }^\circ\text{C}$	0.3			W
		0.75			W
T_{stg}	Storage Temperature	- 55 to 175			$^\circ\text{C}$
T_j	Junction Temperature	175			$^\circ\text{C}$

BC107-BC108-BC109

THERMAL DATA

$R_{th\ j-case}$	Thermal Resistance Junction-case	Max	200	°C/W
$R_{th\ j-amb}$	Thermal Resistance Junction-ambient	Max	500	°C/W

ELECTRICAL CHARACTERISTICS ($T_{amb} = 25\text{ °C}$ unless otherwise specified)

Symbol	Parameter	Test Conditions	Min.	Typ.	Max.	Unit
I_{CBO}	Collector Cutoff Current ($I_E = 0$)	for BC107 $V_{CB} = 40\text{ V}$ $V_{CB} = 40\text{ V}$ $T_{amb} = 150\text{ °C}$ for BC108-BC 109 $V_{CB} = 20\text{ V}$ $V_{CB} = 20\text{ V}$ $T_{amb} = 150\text{ °C}$			15 15 15 15	nA μA μA μA
$V_{(BR)CBO}$	Collector-base Breakdown Voltage ($I_E = 0$)	$I_C = 10\text{ }\mu\text{A}$ for BC107 for BC108 for BC109	50 30 30			V V V
$V_{(BR)CEO}^*$	Collector-emitter Breakdown Voltage ($I_B = 0$)	$I_C = 10\text{ mA}$ for BC107 for BC108 for BC109	45 20 20			V V V
$V_{(BR)EBO}$	Emitter-base Breakdown Voltage ($I_C = 0$)	$I_E = 10\text{ }\mu\text{A}$ for BC107 for BC108 for BC109	6 5 5			V V V
$V_{CE(sat)}^*$	Collector-emitter Saturation Voltage	$I_C = 10\text{ mA}$ $I_B = 0.5\text{ mA}$ $I_C = 100\text{ mA}$ $I_B = 5\text{ mA}$		70 200	250 600	mV mV
V_{BE}^*	Base-emitter Voltage	$I_C = 2\text{ mA}$ $V_{CE} = 5\text{ V}$ $I_C = 10\text{ mA}$ $V_{CE} = 5\text{ V}$	550	650 700	700 700	mV mV
$V_{BE(sat)}^*$	Base-emitter Saturation Voltage	$I_C = 10\text{ mA}$ $I_B = 0.5\text{ mA}$ $I_C = 100\text{ mA}$ $I_B = 5\text{ mA}$		750 900		mV mV
h_{FE}^*	DC Current Gain	$I_C = 2\text{ mA}$ $V_{CE} = 5\text{ V}$ for BC107 for BC107 Gr. A for BC107 Gr. B for BC108 for BC108 Gr. A for BC108 Gr. B for BC108 Gr. C for BC109 for BC109 Gr. B for BC109 Gr. C $I_C = 10\text{ }\mu\text{A}$ $V_{CE} = 5\text{ V}$ for BC107 for BC107 Gr. A for BC107 Gr. B for BC108 for BC108 Gr. A for BC108 Gr. B for BC108 Gr. C for BC109 for BC109 Gr. B for BC109 Gr. C	110 110 200 110 110 200 420 200 200 420 40 40 100 40 40 100	230 180 290 350 180 290 520 350 290 520 120 90 150 120 90 150 270	450 220 450 800 220 450 800 800 450 800 270	

* Pulsed : pulse duration = 300 μs , duty cycle = 1 %.

ELECTRICAL CHARACTERISTICS (continued)

Symbol	Parameter	Test Conditions	Min.	Typ.	Max.	Unit
h_{fe}	Small Signal Current Gain	$I_C = 2 \text{ mA}$ $V_{CE} = 5 \text{ V}$ $f = 1 \text{ kHz}$ for BC107 for BC107 Gr. A for BC107 Gr. B for BC108 for BC108 Gr. A for BC108 Gr. B for BC108 Gr. C for BC109 for BC109 Gr. B for BC109 Gr. C $I_C = 10 \text{ mA}$ $V_{CE} = 10 \text{ V}$ $f = 100 \text{ MHz}$		250 190 300 370 190 300 500 370 300 550		
C_{CBO}	Collector-base Capacitance	$I_E = 0$ $V_{CB} = 10 \text{ V}$ $f = 1 \text{ MHz}$		4	6	pF
C_{EBO}	Emitter-base Capacitance	$I_C = 0$ $V_{EB} = 0.5 \text{ V}$ $f = 1 \text{ MHz}$		12		pF
NF	Noise Figure	$I_C = 0.2 \text{ mA}$ $V_{CE} = 5 \text{ V}$ $R_g = 2 \text{ k}\Omega$ $f = 1 \text{ kHz}$ $B = 200 \text{ Hz}$ for BC107 for BC108 for BC109 $I_C = 0.2 \text{ mA}$ $V_{CE} = 5 \text{ V}$ $R_g = 2 \text{ k}\Omega$ $f = 10 \text{ Hz to } 10 \text{ kHz}$ $B = 15.7 \text{ kHz}$ for BC109		2 2 1.5	10 10 4	dB dB dB
h_{ie}	Input Impedance	$I_C = 2 \text{ mA}$ $V_{CE} = 5 \text{ V}$ $f = 1 \text{ kHz}$ for BC107 for BC107 Gr. A for BC107 Gr. B for BC108 for BC108 Gr. A for BC108 Gr. B for BC108 Gr. C for BC109 for BC109 Gr. B for BC109 Gr. C		4 3 4.8 5.5 3 4.8 7 5.5 4.8 7		k Ω k Ω k Ω k Ω k Ω k Ω k Ω k Ω k Ω k Ω

* Pulsed : pulse duration = 300 μ s, duty cycle = 1 %.

BC107-BC108-BC109

ELECTRICAL CHARACTERISTICS (continued)

Symbol	Parameter	Test Conditions	Min.	Typ.	Max.	Unit
h_{re}	Reverse Voltage Ratio	$I_C = 2 \text{ mA}$ $f = 1 \text{ kHz}$ $V_{CE} = 5 \text{ V}$ for BC107 for BC107 Gr. A for BC107 Gr. B for BC108 for BC108 Gr. A for BC108 Gr. B for BC108 Gr. C for BC109 for BC109 Gr. B for BC109 Gr. C		2.2×10^{-4} 1.7×10^{-4} 2.7×10^{-4} 3.1×10^{-4} 1.7×10^{-4} 2.7×10^{-4} 3.8×10^{-4} 3.1×10^{-4} 2.7×10^{-4} 3.8×10^{-4}		
h_{oe}	Output Admittance	$I_C = 2 \text{ mA}$ $f = 1 \text{ kHz}$ $V_{CE} = 5 \text{ V}$ for BC107 for BC107 Gr. A for BC107 Gr. B for BC108 for BC108 Gr. A for BC108 Gr. B for BC108 Gr. C for BC109 for BC109 Gr. B for BC109 Gr. C		20 13 26 30 13 26 34 30 26 34		μS μS μS μS μS μS μS μS μS μS

* Pulsed : pulse duration = 300 μs , duty cycle = 1 %.

DC Normalized Current Gain.

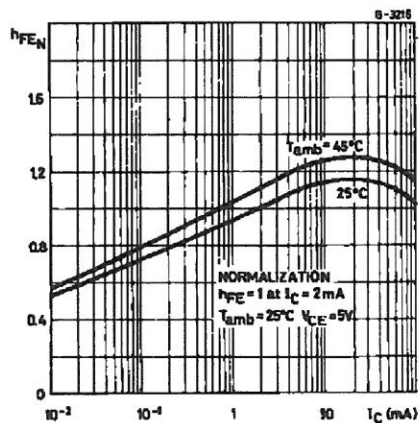

Collector-emitter Saturation Voltage.

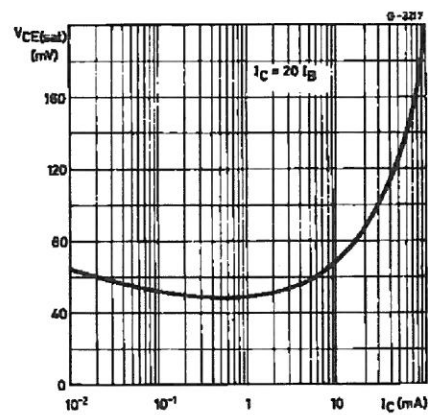

Collector-base Capacitance.

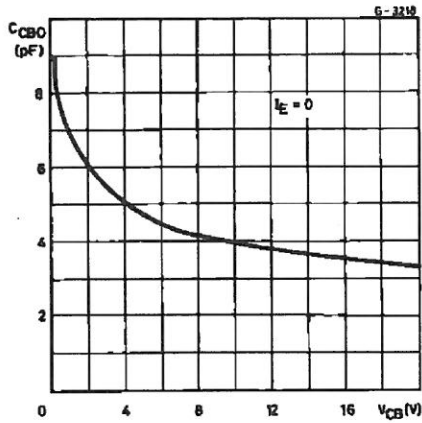

Transition Frequency.

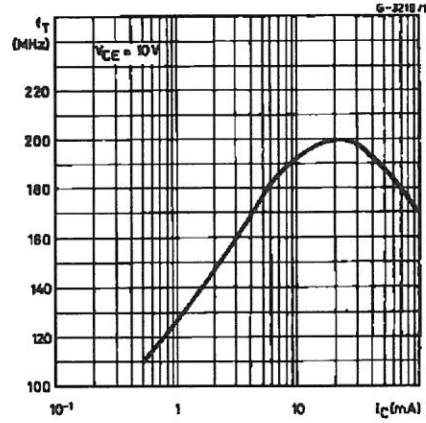

Noise Figure (for BC 109 only).

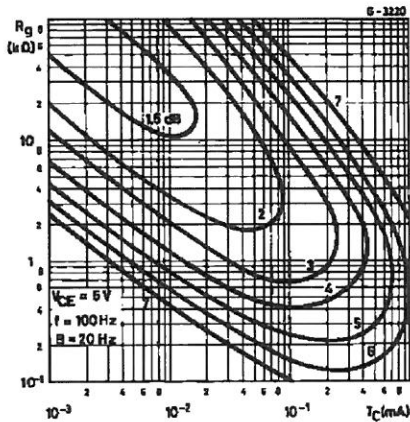

Noise Figure (for BC 109 only).

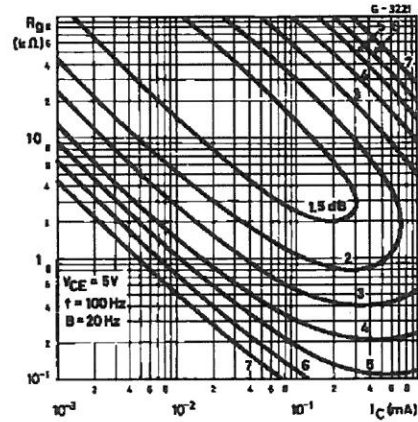

Noise Figure (for BC 109 only).

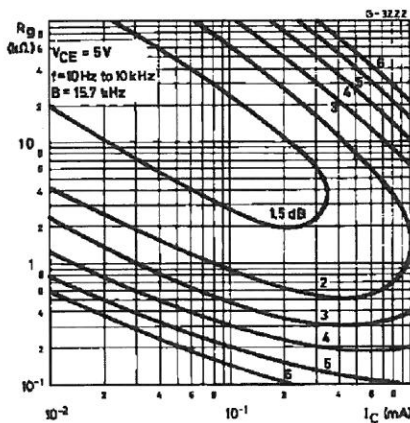

Power Rating Chart.

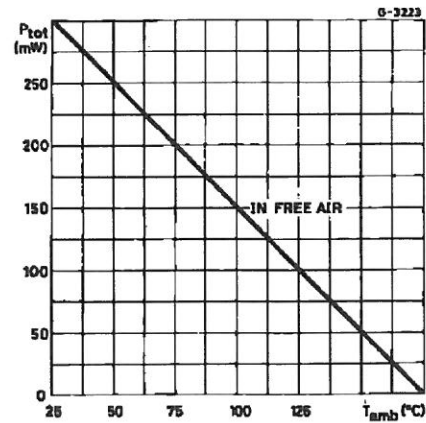

TO-18 MECHANICAL DATA

DIM.	mm			inch		
	MIN.	TYP.	MAX.	MIN.	TYP.	MAX.
A		12.7			0.500	
B			0.49			0.019
D			5.3			0.208
E			4.9			0.193
F			5.8			0.228
G	2.54			0.100		
H			1.2			0.047
I			1.16			0.045
L	45°			45°		

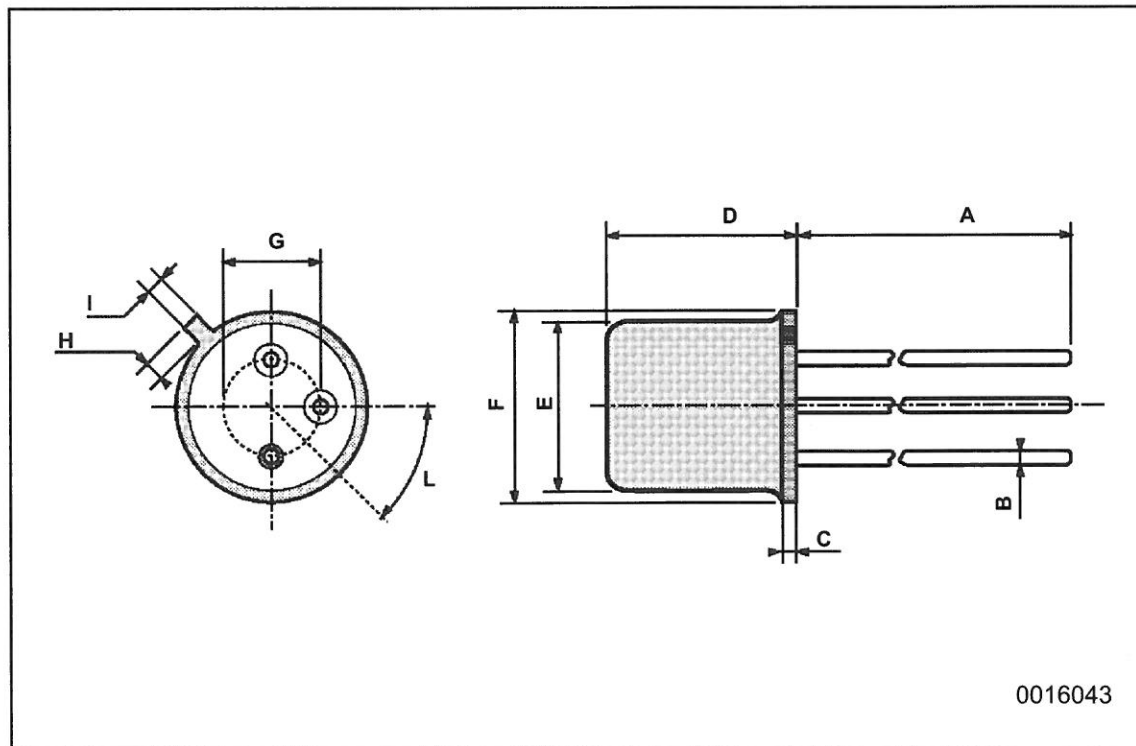

0016043

Information furnished is believed to be accurate and reliable. However, SGS-THOMSON Microelectronics assumes no responsibility for the consequences of use of such information nor for any infringement of patents or other rights of third parties which may result from its use. No license is granted by implication or otherwise under any patent or patent rights of SGS-THOMSON Microelectronics. Specifications mentioned in this publication are subject to change without notice. This publication supersedes and replaces all information previously supplied. SGS-THOMSON Microelectronics products are not authorized for use as critical components in life support devices or systems without express written approval of SGS-THOMSON Microelectronics.

© 1994 SGS-THOMSON Microelectronics - All Rights Reserved

SGS-THOMSON Microelectronics GROUP OF COMPANIES
Australia - Brazil - France - Germany - Hong Kong - Italy - Japan - Korea - Malaysia - Malta - Morocco - The Netherlands -
Singapore - Spain - Sweden - Switzerland - Taiwan - Thailand - United Kingdom - U.S.A